



## Peltier-cooled incubator IPP55

Microbiology, zoology, food, cosmetics or pharma industry: the energy-saving cooled incubator with Peltier elements heats up and cools down seamlessly in one system.



With the help of our model selection, with dimensioned model sketches and extensive technical data for download, you will find your perfect Peltier-cooled incubator. For large volumes in conjunction with rapid temperature changes, the Memmert compressor-cooled incubator is recommended. Flexibility and technical features of our appliances meet all possible needs. Put us to the test!

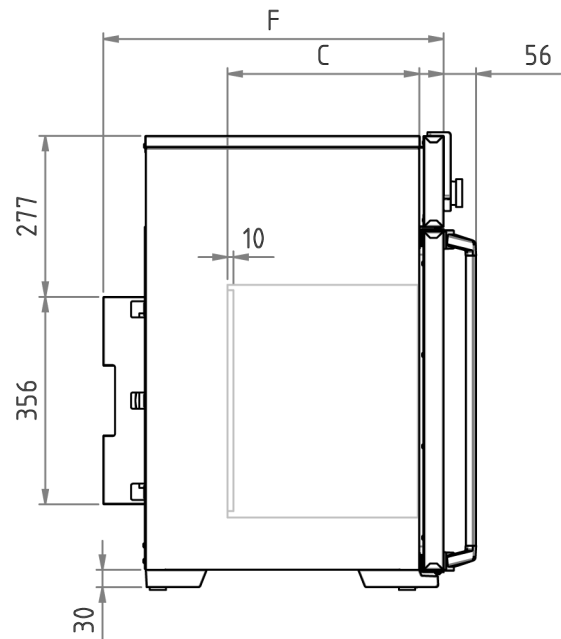
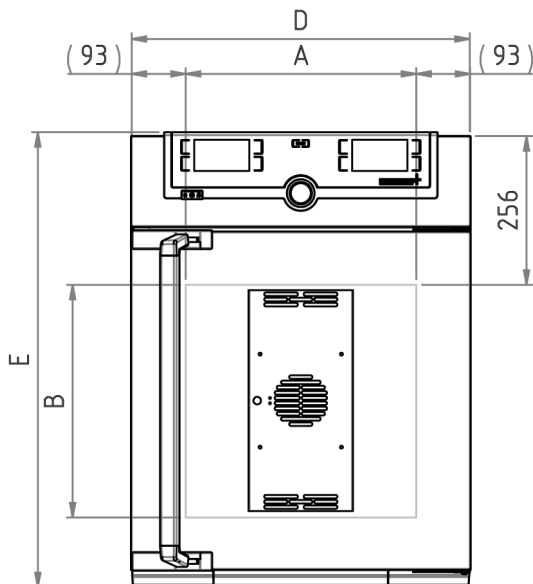

## Temperature

**Working temperature range** from 0°C to +70°C

**Setting accuracy temperature** 0.1 °C

**Temperature** 1 Pt100 sensor DIN class A in 4-wire-circuit

## Control technology

**Language setting** German, English, Spanish, French, Polish, Czech, Hungarian

**ControlCOCKPIT** SingleDISPLAY. Adaptive multifunctional digital PID-microprocessor controller with high-definition TFT-colour display

**Timer** Digital backwards counter with target time setting, adjustable from 1 minute to 99 days

**Function SetpointWAIT** the process time does not start until the set temperature is reached

**Calibration** three freely selectable temperature values

**adjustable parameters** temperature (Celsius or Fahrenheit), programme time, time zones, summertime/wintertime

## Ventilation

**Convection** forced ventilation by Peltier fan

## Communication

**Documentation** programme stored in case of power failure

**Programming** AtmoCONTROL software for reading out, managing and organising the data logger via Ethernet interface (temporary trial version can be downloaded). USB stick with AtmoCONTROL software available as accessory (on demand).

## Safety

**Temperature control** adjustable electronic overtemperature monitor and mechanical temperature limiter

**Autodiagnostic system** for fault analysis

## Heating concept

**Peltier** energy-saving Peltier heating-/cooling system integrated in the rear (heat pump principle)

## Standard equipment

**Door** fully insulated stainless steel door with 2-point locking (compression door lock)

**Internals** 1 stainless steel grid(s), electropolished

**Works calibration certificate** for +10°C and +37°C

**Door** inner glass door

### Stainless steel interior

Volume	53 l
Dimensions	$w_{(A)} \times h_{(B)} \times d_{(C)}$ : 400 x 400 x 330 mm
Max. number of internals	4
Max. loading of chamber	80 kg
Max. loading per internal	20 kg

### Textured stainless steel casing

Dimensions	$w_{(D)} \times h_{(E)} \times d_{(F)}$ : 585 x 784 x 586 mm
Housing	rear zinc-plated steel

### Electrical data

Voltage	230 V, 50/60 Hz
Electrical load	approx. 275 W
Voltage	115 V, 50/60 Hz
Electrical load	approx. 275 W

### Ambient conditions

Set Up	The distance between the wall and the rear of the appliance must be at least 15 cm. The clearance from the ceiling must not be less than 20 cm and the side clearance from walls or nearby appliances must not be less than 5 cm.
Ambient temperature	16 °C to 40 °C
Humidity rh	max. 70 %, non-condensing
Altitude of installation	max. 2,000 m above sea level
Overvoltage category	II
Pollution degree	2

### Packing/shipping data

Transport information	The appliances must be transported upright
Customs tariff number	8419 8998
Country of origin	Federal Republic of Germany
WEEE-Reg.-No.	DE 66812464
Dimensions approx incl. carton	w x h x d: 730 x 950 x 670 mm
Net weight	approx. 52 kg
Gross weight carton	approx. 71 kg

**Standard units are safety-approved and bear the test marks**

